

RODOFLEX

FLEXIBLE COUPLINGS - TORSIONALLY STIFF

GIUNTO FLESSIBILE
TORSIONALMENTE RIGIDI
TRASMISSIONE DI POTENZA

FLEXIBLE COUPLINGS
TORSIONALLY STIFF
POWER TRANSMISSION

JOINT D'ACCOUPEMENT
RIGIDITE A LA TORSION
TRANSMISSION DE PUISSANCE

ATMK..

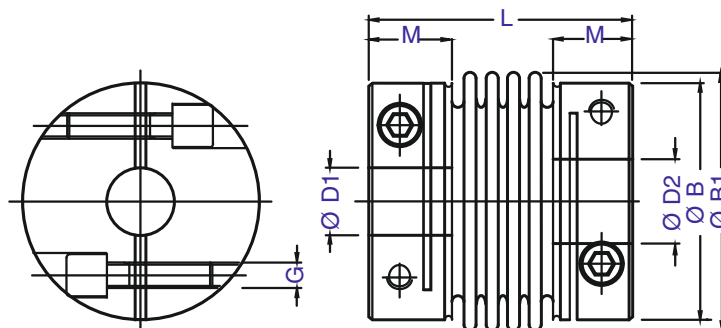

TIPO TYPE TYPE	$\varnothing D^1 - D^2$ MIN MAX mm	$\varnothing B$ mm	$\varnothing B1$ mm	L mm	M mm	G
ATMK 12 .. L48	8 => 15	30	32	48	17	M5
ATMK 16 .. L50	8 => 20	37,5	39,5	50	16	M5
ATMK 15 .. L71	12,7 => 30	51,5	56	71	19,5	M6
ATMK 20 .. L71	12,7 => 30	51,5	56	71	19,5	M6
ATMK 30 .. L77	14 => 32	58	66	77	22,5	M8
ATMK 30 .. L91	14 => 32	58	66	91	22,5	M8
ATMK 60 .. L77	14 => 32	58	66	77	22,5	M8
ATMK 60 .. L91	14 => 32	58	66	91	22,5	M8
ATMK 80 .. L84	18 => 40	72	82	84	26	M10
ATMK 80 .. L98	18 => 40	72	82	98	26	M10
ATMK 170 .. L84	18 => 40	72	82	84	26	M10
ATMK 170 .. L98	18 => 40	72	82	98	26	M10
ATMK 270 .. L92	30 => 60	93	101	92	30	M12
ATMK 320 .. L92	30 => 60	93	101	92	30	M12

\varnothing FORI STANDARD tol. G7

STANDARD \varnothing BORES tol. G7

\varnothing ALESAGES STANDARD tol. G7

TIPO/TYPE	8	9	9,52 3/8"	10	11	12	12,7 1/2"	14	15	16	17	18	19	20	22	24	25	28	30	32
ATMK 12 .. L48	8	9	9,52	10	11	12	12,7	14	15											
ATMK 16 .. L50	8	9		10	11	12		14	15	16		18	19	20						
ATMK 15 .. L71							12,7	14		16	17	18	19	20	22	24	25	28	30	
ATMK 20 .. L71							12,7	14		16	17	18	19	20	22	24	25	28	30	
ATMK 30 .. L77								14	15	16	17	18	19	20	22	24	25	28	30	32
ATMK 30 .. L91								14	15	16	17	18	19	20	22	24	25	28	30	32
ATMK 60 .. L77								14	15	16	17	18	19	20	22	24	25	28	30	32
ATMK 60 .. L91								14	15	16	17	18	19	20	22	24	25	28	30	32
TIPO/TYPE	18	19	20	22	24	25	28	30	32	35	36	38	40	42	46	48	50	55	60	
ATMK 80 .. L84	18	19	20	22	24	25	28	30	32	35	36	38	40							
ATMK 80 .. L98	18	19	20	22	24	25	28	30	32	35	36	38	40							
ATMK 170 .. L84	18	19	20	22	24	25	28	30	32	35	36	38	40							
ATMK 170 .. L98	18	19	20	22	24	25	28	30	32	35	36	38	40							
ATMK 270 .. L92								30	32	35	36	38	40	42	46	48	50	55	60	
ATMK 320 .. L92								30	32	35	36	38	40	42	46	48	50	55	60	

GIUNTO FLESSIBILE TORSIONALMENTE RIGIDI TRASMISSIONE DI POTENZA

- ① COPPIA NOMINALE
- ② DISALLINEAMENTO PARALLELO
- ③ DISALLINEAMENTO IN DISTANZA
- ④ DISALLINEAMENTO ANGOLARE
- ⑤ RIGIDITA' TORSIONALE
- ⑥ MOMENTO D'INERZIA
- ⑦ MOMENTO SERRAGGIO VITI

FLEXIBLE COUPLINGS TORSIONALLY STIFF POWER TRANSMISSION

- ① NOMINAL TORQUE
- ② PARALLEL MISALIGNMENT
- ③ AXIAL DISPLACEMENT
- ④ ANGULAR MISALIGNMENT
- ⑤ TORSIONAL STIFFNESS
- ⑥ MOMENT OF INERTIA
- ⑦ SCREW TIGHTENING TORQUE

JOINT D'ACCOUPEMENT RIGIDITE A LA TORSION TRANSMISSION DE PUISSANCE

- ① COUPLE NOMINAL
- ② MESALIGNEMENT PARALLEL
- ③ DEPLACEMENT AXIAL
- ④ MESALIGNEMENT ANGULAIRE
- ⑤ RIGIDITE' EN TORSION
- ⑥ MOMENT D'INERTIE
- ⑦ MOMENT SERRAGE DES VIS

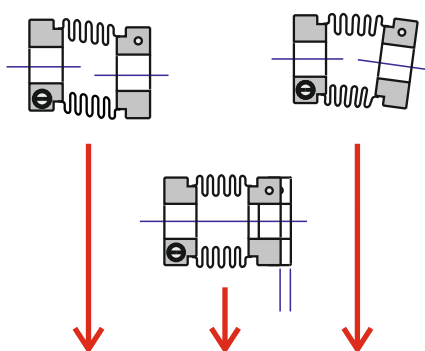

AVVERTENZE
DI MONTAGGIO
IMPORTANTI
cfr. pag. 17

IMPORTANT
MOUNTING
INSTRUCTION
see page 17

AVIS DE
MONTAGE
IMPORTANT
voir page 17



TIPO TYPE TYPE	(1) Nm	(2) PARALL. mm	(3) DIST. mm	(4) ANG. a°	(5) 10 ³ Nm/rad	(6) 10 ⁻³ kgm ²	(7) Nm	 kg
ATMK 12 .. L48	12	0,12	0,25	1,0°	9	0,02	3,5	0,155
ATMK 16 .. L50	16	0,12	0,30	1,0°	11	0,05	3,5	0,235
ATMK 15 .. L71	10	0,15	0,30	1,0°	15	0,20	6	0,515
ATMK 20 .. L71	20	0,15	0,30	1,0°	28	0,22	6	0,535
ATMK 30 .. L77	30	0,15	0,30	1,0°	25	0,39	16	0,775
ATMK 30 .. L91	30	0,15	0,30	1,0°	25	0,40	16	0,785
ATMK 60 .. L77	60	0,15	0,30	1,0°	42	0,44	16	0,820
ATMK 60 .. L91	60	0,15	0,30	1,0°	42	0,45	16	0,835
ATMK 80 .. L84	80	0,20	0,35	1,5°	45	1,05	32	1,420
ATMK 80 .. L98	80	0,20	0,35	1,5°	45	1,07	32	1,430
ATMK 170 .. L84	170	0,20	0,35	1,5°	90	1,15	32	1,480
ATMK 170 .. L98	170	0,20	0,35	1,5°	90	1,19	32	1,505
ATMK 270 .. L92	270	0,20	0,50	2,0°	150	3,56	56	2,690
ATMK 320 .. L92	320	0,20	0,50	2,0°	190	4,26	56	2,780

soffietto metallico:

in acciaio inox 1.4541, saldato ai mozzi

mozzi: acciaio inox 1.4305

fori mozzi:

combinazione di Ø standard, cfr. tabella pag. 8, finiti toll. G7

esempio sigla: tipo ATMK 30, foro D1 Ø 20 mm, foro D2 24 mm, lunghezza totale 91 mm

--> **ATMK 30-20-24 L91**

metallic bellows:

stainless steel 1.4541, welded to hubs

hubs: stainless steel 1.4305

hub bores:

combination of standard Ø, see. pag. 8, finished tol. G7

part numbers: type ATMK 30, bore D1 Ø 20 mm, bore D2 24 mm, overall length 91 mm

--> **ATMK 30-20-24 L91**

soufflet metallique:

acier inoxydable 1.4541, soudé aux moyeux

moyeux: acier inoxydable 1.4305

alésage des moyeux:

combinaison de Ø standard, voir pag. 8, finis tol. G7

exemple de commande: type ATMK 30, alésage D1 Ø 20 mm, alésage D2 24 mm, longueur total 91 mm

--> **ATMK 30-20-24 L91**